

⬅ WARNING ➡

- **Electric Shock Hazard, Use Caution**
- Disconnect and lock out power before installation
- Follow national and local electrical codes
- Read and understand these instructions before installing
- Installation only by qualified electrical personnel
- Do not rely on this device to indicate line power
- Only install this device on insulated conductors
- Only install on 600 Vac maximum conductors
- Do not use this device for life-safety applications
- Do not install in hazardous or classified locations
- Install this product in a suitable electrical enclosure
- **Failure to follow these instructions will result in death or serious injury.**

Specifications

- Measurement Range 0-10/20/50/100/200 Amps
(Select model)
- Maximum Input Current . . . 100 A for 10/20/50 models
200 A for 100 model
250 A for 200 model
- Accuracy ± 1% FSO (5-100% of range)
- Sensor Power Self-powered
- Output Signal 0-5 Vdc
- Insulation Class 600 Vac, insulated conductors
- Frequency 50/60 Hz
- Response Time 200 mS (0-90%)
- Output Load 1 MΩ typical
- Loading Error add 0.5% error with 100 KΩ
- Operating Temperature . . . -15 to 50 °C (5 to 122 °F)
- Operating Humidity 5 to 90 %RH, non-condensing
- Terminal Block 14 to 22 AWG
- Dimensions 3.0 x 3.1 x 0.98 in
(76 x 79 x 24.9 mm)
- Sensor Aperture 0.8 in (20.3 mm)
- Enclosure Material ABS/PC, UL94 V-0
- Manufacturing ISO 9001 Certified
- Agency Approvals cULus Listed

Operation

The SC-650-x current sensors monitor line current for electrical loads such as pumps, conveyors, machine tools or fans and output an analog 0-5 Vdc signal to represent the load current. The sensors requires no external power supply as they are totally powered by induction from the AC line being monitored. The sensors are typically used to monitor motor operation and can be used to determine motor failure, belt loss, machine feed rates or tool wear.

Factory Calibrated Ranges

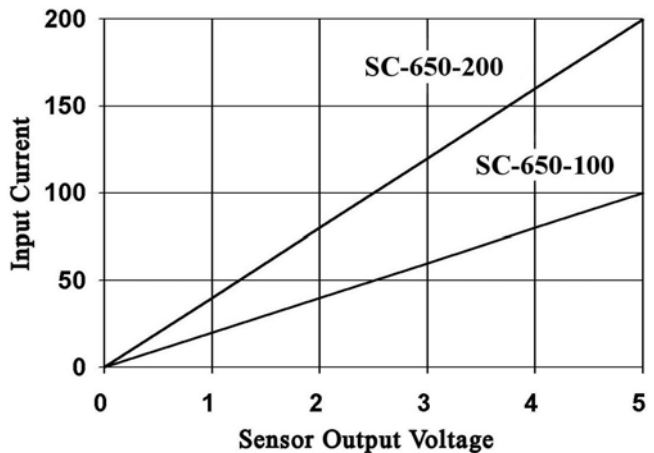
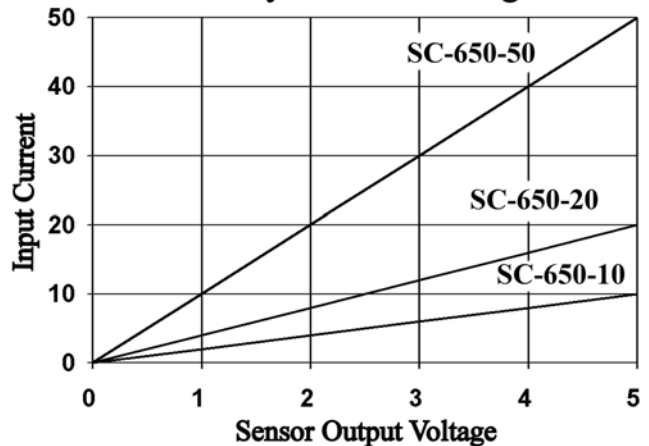

Installation

- Read all warnings before beginning
- Ensure the selected device has the correct ratings
- Disconnect and lock out power
- Mount the sensor with two screws through the base or snap onto a standard DIN mounting rail
- Place the monitored conductor through the sensor hole
- Keep the sensor contacts clean, remove any dirt
- Observe polarity and wire the output to the controller
- Ensure the controller scale matches the sensed range
- Reconnect the power

Dimensions

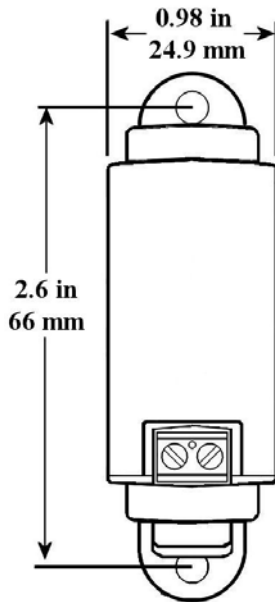
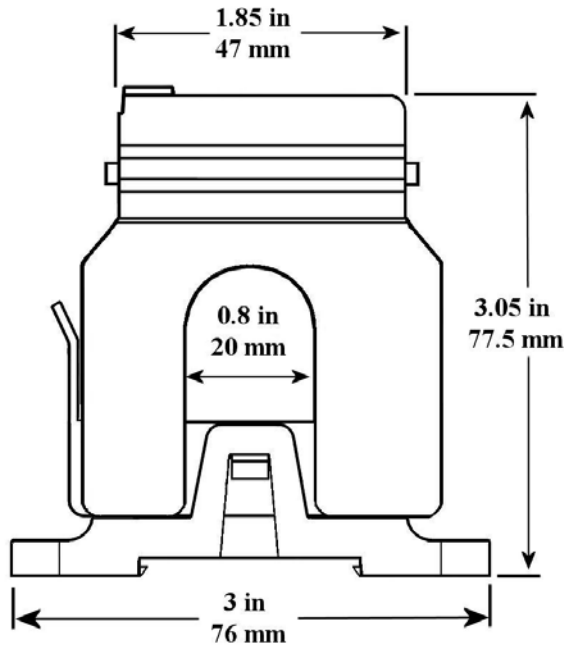

Calibration

All models are factory calibrated to operate within $\pm 1\%$ of FSO. If field calibration is required or a custom measurement range is desired, simply peel back the top label to expose the calibration pot. The adjustment pot sets the current span of the device and may be adjusted by about $\pm 20\%$ of FSO.

Wiring

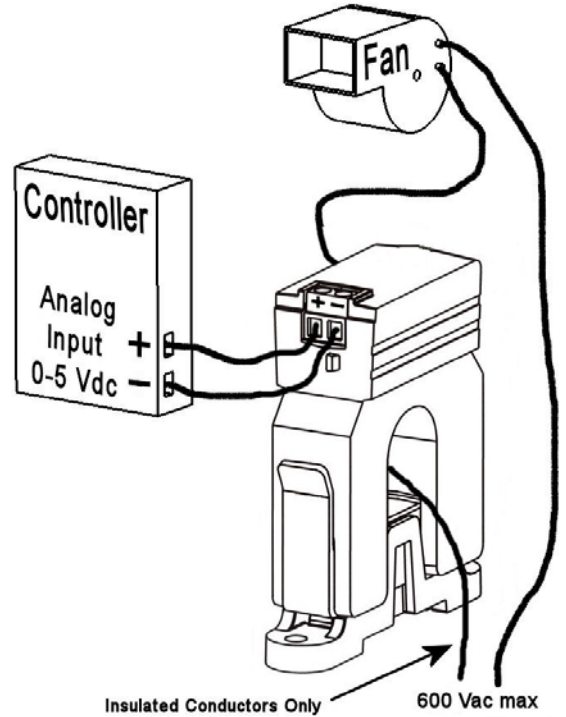

Applications

For applications with load currents exceeding the sensor current range use an external CT to reduce the current to an acceptable value. For example, to measure a 500 Amp load current, use a 500A:5A CT and wrap the CT secondary through the SC-650-10 twice so the sensor output will be 0-5 Vdc = 0-500 Amps.

For applications with small load currents (such as less than 10 Amps), wrap the monitored conductor through the sensor aperture several times to increase the current measured by the sensor. For example, to measure 0-2 Amps with a SC-650-10, wrap the conductor through the sensor aperture 5 times so the sensor output will be 0-5 Vdc = 0-2 Amps.

For external CT or multiple wrap applications, ensure the controller is scaled accordingly to obtain correct readings.

For any application with multiple wraps, note that the SC-650 maximum current rating must be divided by the number of wraps. For example, with one wrap the maximum current is 200 Amps, with 5 wraps the maximum current is $200/5 = 40$ Amps. Ensure the load current is < 40 Amps or the device may overheat and be damaged.

For highest accuracy, always select the correct device for the current range required.