

Dimensions

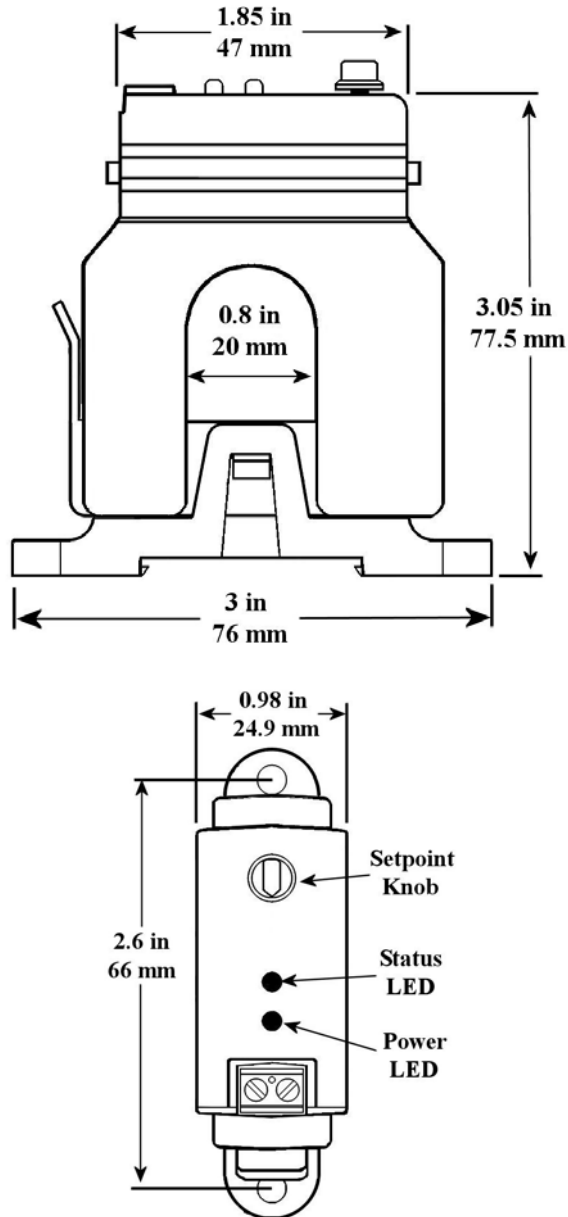

Calibration

With the sensor installed, turn on the monitored load (motor, heater, etc.) and allow it to run normally. Since the SC is factory set to switch at 2 Amps the status LED should be lit and the contacts should be closed if the load draws more than 2 Amps. Rotate the setpoint knob counter-clockwise until the status LED turns off. Then slowly turn the knob clockwise until the status LED just comes on. Turn clockwise slightly more to eliminate false switching. The SC is now set to detect an under-current condition. A voltmeter can be used across the contacts to verify switch operation.

Wiring

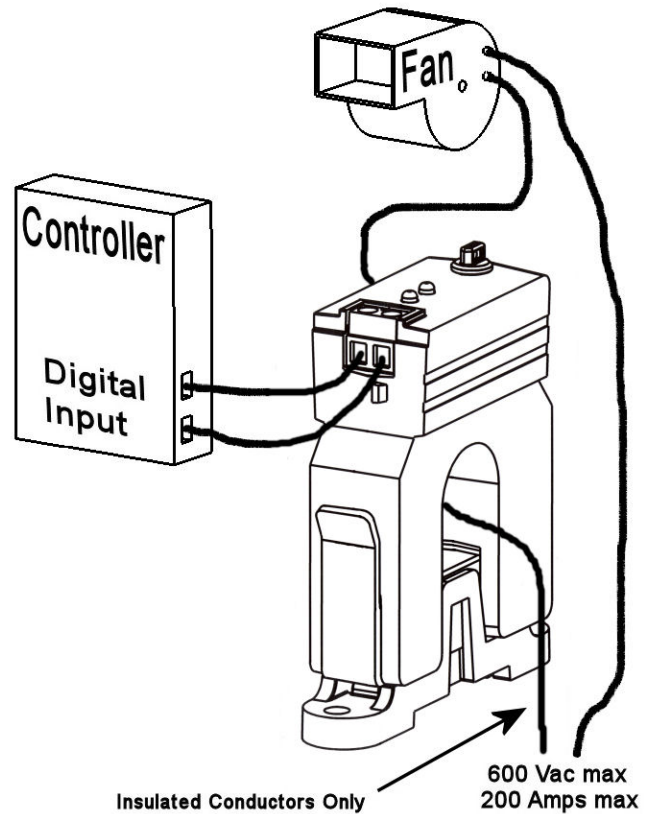

Applications

For applications with load currents exceeding the sensor current range use an external CT to reduce the current to an acceptable value. For example, to monitor a 500 Amp load current, use a 500A:5A CT and wrap the CT secondary through the SC-610-200 four times so the sensor actually only sees 20 Amps when the load current is 500 Amps.

For applications with very small load currents (such as less than 2 Amps), wrap the monitored conductor through the sensor aperture several times to increase the current measured by the sensor. For example, to monitor a 0-1 Amp load with a SC-610-200, wrap the conductor through the sensor aperture 5 times so the sensor actually sees 0-5 Amps.

For any application with multiple wraps, note that the SC-610-200 maximum current rating must be divided by the number of wraps. For example, with one wrap the maximum current is 200 Amps, with 5 wraps the maximum current is $200/5 = 40$ Amps. Ensure the load current is < 40 Amps or the device may overheat and be damaged.