

Introduction

The CO2 detector uses Infrared Technology to monitor CO2 levels within a range of 0 – 2000 ppm. Options include a control relay, override switch, up/down setpoint control, RH sensor and temperature sensor.

The device includes native BACnet protocol with 15 BACnet objects and an RS-485 MS/TP network connection to offer a single-point solution for control of indoor air quality and comfort. Features include a back-lit LCD and user menu for easy installation, field-proven RH sensor and user input controls to add local setpoint and override functions at the same network point.

Before Installation

Read these instructions carefully before installing and commissioning the CO2 detector. Failure to follow these instructions may result in product damage. Do not use in an explosive or hazardous environment, with combustible or flammable gases, as a safety or emergency stop device or in any other application where failure of the product could result in personal injury. Take electrostatic discharge precautions during installation and do not exceed the device ratings.

Set-up

The device parameters must be set before connection to the network and will ensure each device will have a unique MAC address and Device Instance for startup. On startup, the MAC address is appended to the Device Object : Vendor Identifier to create the unique Device Instance (Device Object : Object Identifier). Once connected to a network, the Device Object : Object Identifier can be written to any unique value via BACnet and then the MAC address will no longer be appended to the value. Once set, all parameters are saved in non-volatile memory. The local menu and LCD are used to set the BACnet MAC device address (0-127) and the baud rate. The factory defaults are address 3 and 9600 baud. The menu and setup procedure is described in the Start-up section.

Mounting

The room type sensor installs directly on a standard electrical box and should be mounted five feet from the floor of the area to be controlled. Do not mount the sensor near doors, opening windows, supply air diffusers or other known air disturbances. Avoid areas where the detector is exposed to vibrations or rapid temperature changes.

The cover is hooked to the base at the top edge and must be removed from the bottom edge first. Use a small screwdriver to carefully pry each bottom corner if necessary. If a security screw is installed on the bottom edge, then it may have to be loosened or removed also. Tip the cover away from the base and sit it aside.

The pcb must be removed from the base to access the mounting holes. Follow usual anti-static procedures when handling the pcb and be careful not to touch the sensors. The pcb is removed by pressing the enclosure base to unsnap the latch near the bottom edge, then the pcb can be lifted out of the base. Sit the pcb aside until the base is mounted on the wall.

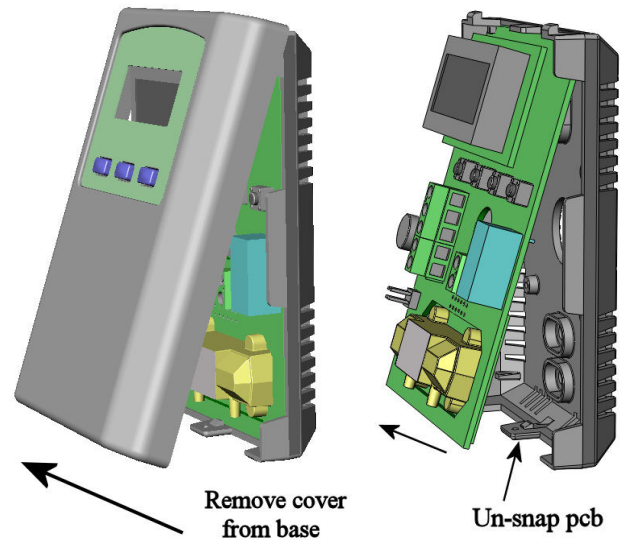

After the base is screwed to an electrical box or the wall using the appropriate holes, pull the wires through the wiring hole in the center of the pcb and then reinstall it in the enclosure base. Ensure the pcb is snapped into the base securely and correctly.

The mounting hole locations are shown in the following drawing.

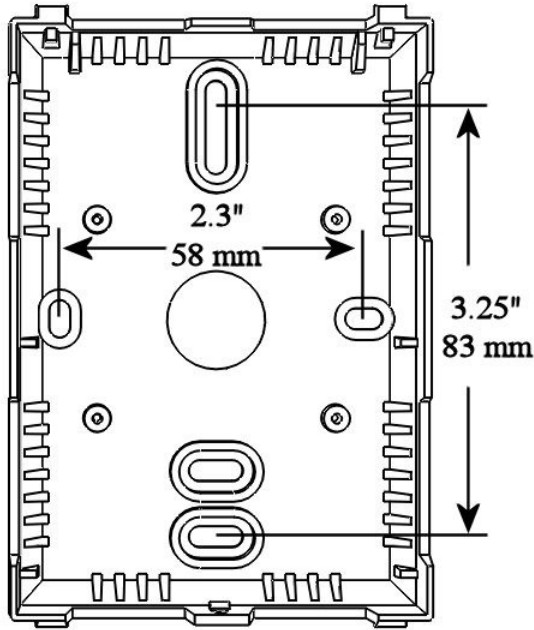

Wiring

Deactivate the 24 Vac/dc power supply until all connections are made to the device to prevent electrical shock or equipment damage. Follow proper electrostatic discharge (ESD) handling procedures when installing the device or equipment damage may occur. Use 22 AWG shielded wiring for all connections and do not locate the device wires in the same conduit with wiring used to supply inductive loads such as motors. Make all connections in accordance with national and local codes.

Connect the 24 Vac/dc power supply to the terminals labeled **POWER** and **COMMON**. Use caution if 24 Vac power is used and one side of the transformer is earth-grounded. In general, the transformer should NOT be connected to earth ground when using devices with RS-485 network connections. The device is reverse voltage protected and will not operate if connected backwards.

Connect the RS-485 network with twisted shielded pair to the terminals marked **A(-)**, **B(+)** and **SHIELD**. The positive wire connects to **B(+)** and the negative wire connects to **A(-)** and the cable shield must be connected to the **SHIELD** terminal on each device. If the device is installed at either end of an RS-485 network, an end-of-line (EOL) termination resistor (121 ohm) should be installed in parallel to the A(-) and B(+) terminals. This device includes a network termination jumper and will connect the 121 ohm resistor correctly on the pcb. Simply move the jumper to the EOL position and no external resistor is required. The ground wire of the shielded pair should be connected to earth ground at the end of the network and the master is not grounded. Do not run bus wiring in the same conduit as line voltage wiring or other wiring that switches power to highly inductive loads such as contactors, coils or motors.

A network segment is a single shielded wire loop run between several devices (nodes) in a daisy chain configuration. The total segment length should be less than 4000 feet (1220 meters) and the maximum number of nodes on one segment is 64. Nodes are any device connected to the loop and include controllers, repeaters and sensors such as the CDD but do not include the EOL terminators. To install more than 64 devices, or to increase the network length, repeaters will be required for proper communication. The maximum daisy chain length (segment) depends on transmission speed (baud rate), wire size and number of nodes. If communication is slow or unreliable, it may be necessary to wire two daisy chains to the controller with a repeater for each segment.

An optional signal is the relay output available on the **N. OPEN** and **RELAY COM** terminals. The Relay COM terminal is NOT connected to the power supply COMMON terminal. The relay output is completely isolated and has a Normally Open (NO) signal. This signal can be used to directly control an alarm or ventilation fan.

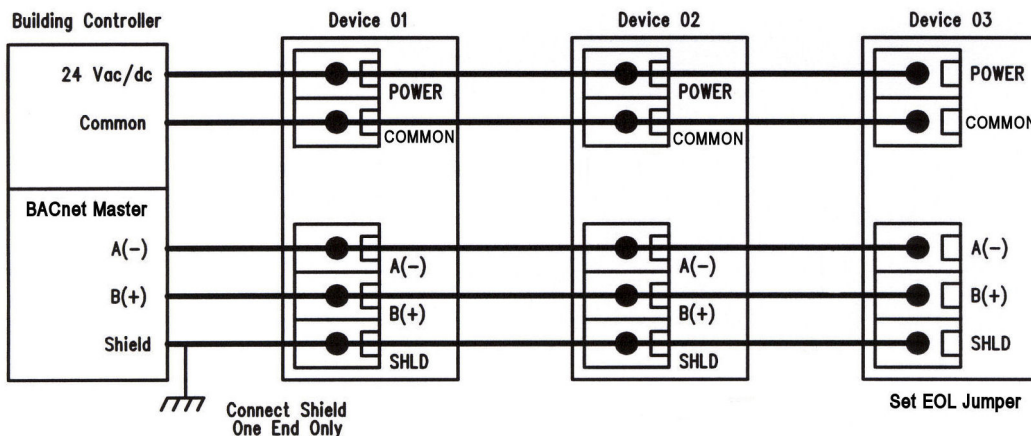

Start-up

Verify the transmitter is properly wired and connections are tight. Apply power and note that the CO2 sensor chamber light flashes on and off. The LCD will indicate the software version number, the Auto Cal status, the MAC ID, the Device Instance and the Baud Rate. Then the device will begin reading the sensor values and display them on the LCD. The sensor operates on a 4 second interval and will update the output and display every 4 seconds.

Operation

In normal operation the device reads the CO2, RH and temperature sensors and updates the object values accordingly. The LCD displays the sensor values as determined by the display mode object.

If the device has the optional Up/Down setpoint switches installed, pressing either the <UP> or <DOWN> keys will cause the LCD to change to show the setpoint value. The first key press will display the current setting of the Up/Down control from 0 to 100%. The display will show "Setpoint - xx%" for about 5 seconds and then revert back to the sensor values again if neither the <UP> or <DOWN> keys are pressed again. To increase the setpoint, press the <UP> key while the LCD is in setpoint mode and each press will increase the setpoint by 10% up to the 100% maximum value. To decrease the setpoint, press the <DOWN> key while the LCD is in setpoint mode and each press will decrease the setpoint by 10% down to the 0% minimum value. After 5 seconds of no key activity, the display will revert back to normal and the new setpoint value will be saved.

If the device has the optional Override switch installed, pressing the <OVERRIDE> key will cause the LCD to change to show the override status. The display will show "Override - ON" for about 5 seconds and then revert back to the sensor values again. The override cannot be turned OFF with the switch, it must be reset via the BACnet Override_Switch object.

Setup Menu

The menu has several items as shown below. To enter the menu, press and release the <MENU> key while in normal operation. This will enter the SETUP menu step 1, pressing the <MENU> key a second time advances to step 2. Each press of the <MENU> key advances the menu item. No values are saved or changed by using the <MENU> key. The <UP> and <DOWN> keys are used to make changes to program variables by scrolling through the available options. When a value is changed, use the <SAVE> key to save it to memory and advance to the next menu item.

- <MENU> Press and release the <MENU> key to enter the SETUP menu
- 1. MAC Addr 3 Press the <UP> or <DOWN> keys to select a unique network address from 0-127. Press the <SAVE> key to save the change. The factory default BACnet MAC address is 3.

- <MENU>
- 2. BaudRate 9600 Use the <UP> or <DOWN> keys to select a baud rate of 9600, 19200, 38400 or 76800. Press the <SAVE> key to save the change. The factory default BACnet baud rate is 9600.

- <MENU>
- 3. Calibrat 1000 PPM This item is used for 1000 ppm gas calibration and is explained in the *Calibration* section.

<MENU>

Item 4 is only available if the Relay Option is installed, otherwise the menu skips directly to step 5.

- 4. Relay Test OFF Use the <UP> or <DOWN> keys to toggle the relay ON or OFF. Press the <MENU> key to turn the relay off and advance to the next item.

<MENU>

Item 5 is only available if the cover is equipped with a viewable LCD, otherwise the menu skips directly to step 6.

- 5. BackLite Enable Use the <UP> or <DOWN> keys to enable or disable the LCD backlight. When enabled the backlight is always on, when disabled it never lights. Press the <SAVE> key to save the setting. The factory default is Enable.

- <MENU>
- 6. Menu Exit Press <SAVE> to exit the menu and return to normal operation or <MENU> to repeat the menu.

BACnet Overview

Using the BACnet system software, only map the point objects that are installed and required. Excessive point mapping will lower the network performance. On the CDD some objects will not be available if the hardware option is not installed. For example, AI 4 will not be available if there is no Setpoint controls installed. This could also be the case is the device has no

RH, temperature or relay options. This can be determined via BACnet by checking the Reliability property of the optional objects.

If the hardware is not installed, the Reliability property will return NO_SENSOR and the Event_State property will indicate FAULT if the related hardware is not installed. To reduce network traffic, these points should not be polled.

The CDD product has 15 BACnet objects to identify the device, read current values, configure the device, control the alarm and calibrate the sensors. There are five standard supported BACnet object types as shown below.

Object Type	Dynamically Creatable	Dynamically Deletable	Object Identifier	Object Name
Device	No	No	381003	CDD_CO2_Detector_003
Analog Input	No	No	AI 1 AI 2 AI 3 AI 4	CO2_Level Relative_Humidity Temperature Up/Down Control
Analog Value	No	No	AV 1 AV 2 AV 3 AV 4 AV 5 AV 6	Relay_Setpoint Relay_Hysteresis Temperature_Offset Relative_Humidity_Offset Sensor_Altitude Display_Modes
Binary Value	No	No	BV 1 BV 2 BV 3	Override_Switch Auto_Cal_Enable Fahrenheit
Binary Input	No	No	BI 1	Relay_On

The BACnet Device object allows configuration of the CO2 device. Device object properties are shown below.

Property	Default Value	Property Data Type	Access
Object Identifier	381003	BACnetObjectIdentifier(numeric)	Read / Write
Object Name	CDD_CO2_Detector_003	CharacterString (32)	Read / Write
Object Type	DEVICE (8)	BACnetObjectType	Read
System Status	OPERATIONAL (0)	BACnetDeviceStatus	Read
Vendor Name	Greystone Energy Systems	CharacterString	Read
Vendor Identifier	381	Unsigned16	Read
Model Name	CDD2A	CharacterString	Read
Firmware Revision	1.4	CharacterString	Read
Application Software Version	V1.0	CharacterString	Read
Location	150 English Drive, Moncton, NB	CharacterString (32)	Read / Write
Description	Greystone CO2 Detector	CharacterString (32)	Read / Write
Protocol Version	1	Unsigned	Read
Protocol Revision	7	Unsigned	Read
Protocol Services Supported	See description below	BACnetServicesSupported	Read
Protocol Object Types Supported	See description below	BACnetObjectTypesSupported	Read
Object List	See description below	BACnetArray	Read
Maximum APDU Length Accepted	128, B'0010'	Unsigned	Read
Segmentation Supported	NO_SEGMENTATION (3)	BACnetSegmentation	Read
APDU Timeout	10,000	Unsigned	Read / Write
Number of APDU Retries	3	Unsigned	Read / Write
Max Master	127	Unsigned	Read / Write
Max Info Frames	1	Unsigned	Read
Device Address Binding	empty	BACnetAddressBinding	Read
Database Revision	0	Unsigned	Read

- Object_Identifier** Initial default number is 381003, where 381 is the vendor ID and 003 is the default network MAC address. When the MAC address is initially changed the value is updated and saved. For example, if the MAC address is set to 50 via the menu for startup, then the device instance will be set to 381050. This property is also writable via BACnet. If the Device:Object_Identifier is written to via BACnet then the MAC address is no longer appended to the vendor ID to create this value.
- Object_Name** Initial string is “CDD_CO2_Detector_003” where CDD is the device model name and 003 is the default network address. Can be written with a new string of maximum length of 32 characters and the value is saved. The “003” is the MAC address as set by the menu and is automatically changed if the MAC address is changed. Once written to via BACnet, the MAC address no longer gets appended to the value.
- Protocol_Services_Supported** readProperty, writeProperty, deviceCommunicationControl, who-Has, who-Is
Binary bit string = {00000000 00001001 01000000 00000000 01100000}
- Protocol_Object_Types_Supported** Analog_Input, Analog_Value, Binary_Input, Binary_Value, Device
Binary bit string = {10110100 10000000 00000000 00000000}
- Object_List** ((Device, Instance 3), (Analog Input, Instance 1), (Analog Input, Instance 2), (Analog Input, Instance 3), (Analog Input, Instance 4), (Analog Value, Instance 1), (Analog Value, Instance 2), (Analog Value, Instance 3), (Analog Value, Instance 4), (Analog Value, Instance 5), (Analog Value, Instance 6), (Binary Value, Instance 1), (Binary Value, Instance 2), (Binary Value, Instance 3), (Binary Input, Instance 1))
- APDU_Timeout** Value is 10,000. Can be modified from 0 to 10,000.
- Number_Of_APDU_Retries** Value is 3. Can be modified from 0 to 10.
- Max_Master** Value is 127. Value is saved. Can be modified from 0 to 127.
- Database_Revision** Value is 0 to 255.

The four analog input BACnet objects allow reading of current sensor values and indicate which optional sensors are present via the reliability property. Analog input object properties are shown below.

Analog input object CO2_Level (Present_Value is current CO2 sensor reading in ppm. Resolution is 1 ppm.)

Property	Default Value	Property Data Type	Access
Object Identifier	AI1 (Analog Input 1)	BACnetObjectIdentifier	Read
Object Name	CO2_Level	CharacterString (32)	Read
Object Type	ANALOG_INPUT (0)	BACnetObjectType	Read
Present Value	current reading	Real	Read
Description	CO2 Level	CharacterString (32)	Read
Device Type	0-2000 ppm CO2 Sensor	CharacterString (32)	Read
Status Flags	{false, false, false, false} (0000)	BACnetStatusFlags	Read
Event State	NORMAL (0)	BACnetEventState	Read
Reliability	NO_FAULT_DETECTED (0)	BACnetReliability	Read
Out of Service	FALSE (0)	Boolean	Read
Units	parts-per-million (96)	BACnetEngineeringUnits	Read

Analog input object Relative_Humidity (Present_Value is current RH sensor reading in %RH. Resolution is 1 %RH.)

Property	Default Value	Property Data Type	Access
Object Identifier	AI2 (Analog Input 2)	BACnetObjectIdentifier	Read
Object Name	Relative_Humidity	CharacterString (32)	Read
Object Type	ANALOG_INPUT (0)	BACnetObjectType	Read
Present Value	current reading	Real	Read
Description	Relative Humidity	CharacterString (32)	Read
Device Type	0-100 %RH Sensor	CharacterString (32)	Read
Status Flags	{false, false, false, false} (0000) or (1100) if no sensor	BACnetStatusFlags	Read
Event State	NORMAL (0) or FAULT (1) if no sensor	BACnetEventState	Read
Reliability	NO_FAULT_DETECTED (0) or NO_SENSOR (1)	BACnetReliability	Read
Out of Service	FALSE (0)	Boolean	Read
Units	Percent-relative-humidity (29)	BACnetEngineeringUnits	Read

Analog input object Temperature (Present_Value is current temperature sensor reading in °F or °C.)

Property	Default Value	Property Data Type	Access
Object Identifier	AI3 (Analog Input 3)	BACnetObjectIdentifier	Read
Object Name	Temperature	CharacterString (32)	Read
Object Type	ANALOG_INPUT (0)	BACnetObjectType	Read
Present Value	current reading	Real	Read
Description	Temperature	CharacterString (32)	Read
Device Type	0-35 C Temperature Sensor or 32-95 F Temp...Sensor	CharacterString (32)	Read
Status Flags	{false, false, false, false} (0000) or (1100) if no sensor	BACnetStatusFlags	Read
Event State	NORMAL (0) or FAULT (1) if no sensor	BACnetEventState	Read
Reliability	NO_FAULT_DETECTED (0) or NO_SENSOR (1)	BACnetReliability	Read
Out of Service	FALSE (0)	Boolean	Read
Units	degrees-Fahrenheit (64) or degrees-Celsius (62)	BACnetEngineeringUnits	Read

Device_Type String value is either “0-35 C Temperature Sensor” or “32-95 F Temperature Sensor”.
This value changes depending on the BV3 object (Fahrenheit) Present_Value property.

Analog input object Setpoint_Control (Present_Value is current value from 0-100 %. Resolution is 10 %.)

Property	Default Value	Property Data Type	Access
Object Identifier	AI4 (Analog Input 4)	BACnetObjectIdentifier	Read
Object Name	Setpoint_Control	CharacterString (32)	Read
Object Type	ANALOG_INPUT (0)	BACnetObjectType	Read
Present Value	current reading	Real	Read
Description	Setpoint Value	CharacterString (32)	Read
Device Type	0-100 % Setpoint	CharacterString (32)	Read
Status Flags	{false, false, false, false} (0000) or (1100) if no sensor	BACnetStatusFlags	Read
Event State	NORMAL (0) or FAULT (1) if no sensor	BACnetEventState	Read
Reliability	NO_FAULT_DETECTED (0) or NO_SENSOR (1)	BACnetReliability	Read
Out of Service	FALSE (0)	Boolean	Read
Units	percent (98)	BACnetEngineeringUnits	Read

The six analog value BACnet objects allow configuration of the relay parameters, calibration of the temperature and RH readings, setting the CO2 elevation parameter and configuring the LCD display information. Analog value object properties are shown below.

Analog value object Relay_Setpoint (Present_Value defaults to 1000 ppm. Can be set from 500 to 1500 ppm. Resolution is 1 ppm.)

Property	Default Value	Property Data Type	Access
Object Identifier	AV1 (Analog Value 1)	BACnetObjectIdentifier	Read
Object Name	Relay_Setpoint	CharacterString (32)	Read
Object Type	ANALOG_VALUE (2)	BACnetObjectType	Read
Present Value	1000	Real	Read / Write
Description	Relay Setpoint	CharacterString (32)	Read
Status Flags	{false, false, false, false} (0000)	BACnetStatusFlags	Read
Event State	NORMAL (0)	BACnetEventState	Read
Out of Service	FALSE (0)	Boolean	Read
Units	Parts-per-million (96)	BACnetEngineeringUnits	Read

Analog value object Relay_Hysteresis (Present_Value defaults to 50 ppm. Can be set from 25 to 200 ppm. Resolution is 1 ppm.)

Property	Default Value	Property Data Type	Access
Object Identifier	AV2 (Analog Value 2)	BACnetObjectIdentifier	Read
Object Name	Relay_Hysteresis	CharacterString (32)	Read
Object Type	ANALOG_VALUE (2)	BACnetObjectType	Read
Present Value	50	Real	Read / Write
Description	Relay Hysteresis	CharacterString (32)	Read
Status Flags	{false, false, false} (0000)	BACnetStatusFlags	Read
Event State	NORMAL (0)	BACnetEventState	Read
Out of Service	FALSE (0)	Boolean	Read
Units	Parts-per-million (96)	BACnetEngineeringUnits	Read

Analog value object Temperature_Offset (Present_Value defaults to 0 for no offset. Can be set from -5 to +5 Δ°F.)

Property	Default Value	Property Data Type	Access
Object Identifier	AV3 (Analog Value 3)	BACnetObjectIdentifier	Read
Object Name	Temperature_Offset	CharacterString (32)	Read
Object Type	ANALOG_VALUE (2)	BACnetObjectType	Read
Present Value	0	Real	Read / Write
Description	Temperature Offset Calibration	CharacterString (32)	Read
Status Flags	{false, false, false} (0000)	BACnetStatusFlags	Read
Event State	NORMAL (0)	BACnetEventState	Read
Out of Service	FALSE (0)	Boolean	Read
Units	delta-degrees-Fahrenheit (120)	BACnetEngineeringUnits	Read

Analog value object Relative_Humidity_Offset (Present_Value defaults to 0 for no offset. Can be set from -10 to +10 %.)

Property	Default Value	Property Data Type	Access
Object Identifier	AV4 (Analog Value 4)	BACnetObjectIdentifier	Read
Object Name	Relative_Humidity_Offset	CharacterString (32)	Read
Object Type	ANALOG_VALUE (2)	BACnetObjectType	Read
Present Value	0	Real	Read / Write
Description	RH Offset Calibration	CharacterString (32)	Read
Status Flags	{false, false, false, false} (0000)	BACnetStatusFlags	Read
Event State	NORMAL (0)	BACnetEventState	Read
Out of Service	FALSE (0)	Boolean	Read
Units	percent-relative-humidity (29)	BACnetEngineeringUnits	Read

Analog value object Sensor_Altitude (Present_Value defaults to 0 feet. Can be set from 0 to 5000 ft. Resolution is 500 ft.)

Property	Default Value	Property Data Type	Access
Object Identifier	AV5 (Analog Value 5)	BACnetObjectIdentifier	Read
Object Name	Sensor_Altitude	CharacterString (32)	Read
Object Type	ANALOG_VALUE (2)	BACnetObjectType	Read
Present Value	0	Real	Read / Write
Description	CO2 Sensor Altitude	CharacterString (32)	Read
Status Flags	{false, false, false, false} (0000)	BACnetStatusFlags	Read
Event State	NORMAL (0)	BACnetEventState	Read
Out of Service	FALSE (0)	Boolean	Read
Units	feet (33)	BACnetEngineeringUnits	Read

Analog value object Display_Modes

Property	Default Value	Property Data Type	Access
Object Identifier	AV6 (Analog Value 6)	BACnetObjectIdentifier	Read
Object Name	Display_Modes	CharacterString (32)	Read
Object Type	ANALOG_VALUE (2)	BACnetObjectType	Read
Present Value	0	Real	Read / Write
Description	CO2 LCD Display Modes	CharacterString (32)	Read
Status Flags	{false, false, false, false} (0000)	BACnetStatusFlags	Read
Event State	NORMAL (0)	BACnetEventState	Read
Out of Service	FALSE (0)	Boolean	Read
Units	no-units (95)	BACnetEngineeringUnits	Read

Present_Value Real value. The default value depends on the hardware installed. It will default to display all available input signals. Can be set to either 0, 1, 2 or 3 to indicate various LCD display modes. 0 = CO2 only, 1 = CO2 + RH, 2 = CO2 + T, 3 = CO2 + RH + T

The three binary value BACnet objects allow configuration of the auto-cal feature of the CO2 sensor, changing units from °F to °C and reading the override switch status. Binary value object properties are shown below.

Binary value object Override_Switch

Property	Default Value	Property Data Type	Access
Object Identifier	BV1 (Binary Value 1)	BACnetObjectIdentifier	Read
Object Name	Override_Switch	CharacterString (32)	Read
Object Type	BINARY_VALUE (5)	BACnetObjectType	Read
Present Value	INACTIVE (0)	BACnetBinaryPV	Read / Write
Description	Override Switch	CharacterString (32)	Read
Status Flags	{false, false, false, false} (0000) or (1100) if no switch	BACnetStatusFlags	Read
Event State	NORMAL (0) or FAULT (1) if no switch	BACnetEventState	Read
Reliability	NO_FAULT_DETECTED (0) or NO_SENSOR (1)	BACnetReliability	Read
Out of Service	FALSE (0)	Boolean	Read

Present_Value Value is 1 (ACTIVE) if the override switch has been pressed. This value is not saved. To reset, change to 0 (INACTIVE).

Binary value object Auto_Cal_Enable (Present_Value defaults to 1 (ACTIVE) for ON. Can be set to 0 (INACTIVE) for OFF.)

Property	Default Value	Property Data Type	Access
Object Identifier	BV2 (Binary Value 2)	BACnetObjectIdentifier	Read
Object Name	Auto_Cal_Enable	CharacterString (32)	Read
Object Type	BINARY_VALUE (5)	BACnetObjectType	Read
Present Value	ACTIVE (1)	BACnetBinaryPV	Read / Write
Description	Auto Calibration Enable	CharacterString (32)	Read
Status Flags	{false, false, false, false} (0000)	BACnetStatusFlags	Read
Event State	NORMAL (0)	BACnetEventState	Read
Reliability	NO_FAULT_DETECTED (0)	BACnetReliability	Read
Out of Service	FALSE (0)	Boolean	Read

Binary value object Fahrenheit (Present_Value defaults to 1 (ACTIVE) for Fahrenheit. Can be set to 0 (INACTIVE) for Celsius.)

Property	Default Value	Property Data Type	Access
Object Identifier	BV3 (Binary Value 3)	BACnetObjectIdentifier	Read
Object Name	Fahrenheit	CharacterString (32)	Read
Object Type	BINARY_VALUE (5)	BACnetObjectType	Read
Present Value	ACTIVE (1)	BACnetBinaryPV	Read / Write
Description	Fahrenheit (1) or Celsius (0)	CharacterString (32)	Read
Status Flags	{false, false, false, false} (0000) or (1100) if no sensor	BACnetStatusFlags	Read
Event State	NORMAL (0) or FAULT (1) if no temperature sensor	BACnetEventState	Read
Reliability	NO_FAULT_DETECTED (0) or NO_SENSOR (1)	BACnetReliability	Read
Out of Service	FALSE (0)	Boolean	Read

The binary input BACnet object indicates the relay status. Binary input object properties are shown below.

Binary input object Relay_On (Present_Value is 1 (ACTIVE) if the relay is energized, 0 (INACTIVE) if not energized.)

Property	Default Value	Property Data Type	Access
Object Identifier	B11 (Binary Input 1)	BACnetObjectIdentifier	Read
Object Name	Relay_On	CharacterString (32)	Read
Object Type	BINARY_INPUT (3)	BACnetObjectType	Read
Present Value	INACTIVE (0)	BACnetBinaryPV	Read
Description	Relay Status	CharacterString (32)	Read
Device Type	Indicates On/Off Status of Relay	CharacterString (32)	Read
Status Flags	{false, false, false, false} (0000) or (1100) if no relay	BACnetStatusFlags	Read
Event State	NORMAL (0) or FAULT (1) if no relay	BACnetEventState	Read
Reliability	NO_FAULT_DETECTED (0) or NO_SENSOR (1)	BACnetReliability	Read
Out of Service	FALSE (0)	Boolean	Read
Polarity	NORMAL (0)	BACnetPolarity	Read

BACnet Trouble-shooting

The CO2 device operates as a slave. It will not communicate unless a master is connected to the network and sends a request for information, then the slave will answer. If the device does not communicate properly, first check that the communication wires are not reversed. Then check communication parameters set in the menu.

The default BACnet MAC address is 3 and each device must have a unique address to communicate properly. Use the Setup menu to change the MAC address to a unique number for each unit. Ensure the device object name and device object identifier are unique on the entire BACnet network, not just on the MS/TP sub-network. Both of these properties are writable in the device object.

The CDD automatically selects a device object name for itself using the format CDD_CO2_Detector_xxx, where xxx is the MS/TP MAC address (000 to 127) as set in the menu. If this name is changed by writing to the device Object_Name property via BACnet, then the MAC number will no longer be appended to the object name.

The CDD also automatically selects a device object identifier for itself using the format 381xxx, where xxx is the MS/TP MAC address (000 to 127) as set by the menu. If this ID is changed by writing to the device Object_Identifier property via BACnet, then the MAC number will no longer be appended to the object ID.

The default BACnet baud rate is 9600. Use the Setup menu to change the baud rate to the correct setting.

Ensure the application software (graphical interface) is not set to poll the devices too frequently. For example, if the software is polling the devices every 500 mS, the network could be heavily congested with the network traffic and may not operate reliably. A slower polling rate such as 5 to 10 seconds will usually produce better results on a typical network segment. Also consider that the CDD device only updates it's values on a 4 second period due to the time required to do CO2 sampling and analysis.

Use care when setting the MS/TP MAC address (via the menu) and the device object Max_Master property since both can have a significant effect on the network efficiency. Some MAC address and Max_Master combinations will operate more efficiently than others. MAC addresses should be selected sequentially, starting at the lowest possible value.

For example, on a five node segment, the CDD MAC addresses should be set to 1, 2, 3, 4 and 5. In this case, if the Max_Master property value is left at the 127 default, then there will be a lot of wasted time on the network polling for masters that are not present. In this example, the five CDD nodes should be set such that Max_Master is equal to 5. The Max_Master value initially defaults to 127 so that any master can be found when the CO2 device first starts.

Calibration

Calibration with gas requires a field calibration kit consisting of an LCD, a bottle of 1000 ppm CO2 gas, a tank pressure regulator with flow restrictor and the necessary tubing to connect to the device.

Note that because of the Automatic Calibration Mode and other technology incorporated into the CDD series, only a single point 1000 ppm calibration is required to meet specified accuracy.

Turn the regulator on/off knob fully off and attach it to the 1000 ppm CO2 gas bottle and firmly tighten it by hand. Remove the cover of the unit to be calibrated to expose the gas sensor chamber. The tubing from the gas bottle can be connected to either port on the chamber after the plastic cap is removed. Gently remove one cap and connect the tubing, note that strong shock or vibration can affect calibration.

Ensure the device has been operating normally for at least five minutes before applying gas. Slowly turn the valve knob on the regulator to let the gas begin flowing.

The regulator will restrict the flow rate to the specified 100 ml/min. After a brief period the gas will flow into the chamber and the CO2 reading on the LCD will begin to approach 1000 ppm. Wait 1 to 2 minutes until the CO2 reading stabilizes.

Enter the Setup menu and use the <MENU> key to advance to **Calibrat 1000 PPM**. Press and hold the <SAVE> key for 2 seconds and the display will change to **Waiting Calibrat** then to **Waiting 5 minute** to indicate that the process of reprogramming the internal calibration setting is taking place.

This calibration process takes about 5 minutes and the LCD will count down the minutes. Do not disturb the unit or the gas flow during this period. When calibration is complete the unit will display **Calibrat Done**. Press the <SAVE> key to return to normal operation and then the gas can be shut off.

Disconnect the tubing and replace the cap on the sensor chamber as calibration is complete.

General Specifications

- Power Supply 20 – 28 Vac/dc (non-isolated half-wave rectified)
- Consumption 80 mA max @ 24 Vdc, 140 mA max @ 24 Vac with all options
- Protection Circuitry Reverse voltage protected, overvoltage protected
- Operating Conditions 0-50 °C (32-122 °F), 0-95 %RH non-condensing
- Wiring Connections Screw terminal block (14 to 22 AWG)
- Sensor Coverage Area 100 m² (1000 ft²) typical
- Enclosure Wall mount enclosure, 3.3”w x 4.7”h x 1.15”d (84 x 119 x 29 mm)

CO2 Signal

- Measurement Type Non-Dispersive Infrared (NDIR), diffusion sampling
- Measurement Range 0-2000 ppm
- Standard Accuracy ± 75 ppm @ 1000 ppm @ 22 °C (72 °F) compared to certified calibration gas
- Temperature Dependence 0.2 %FS per °C
- Stability < 2 %FS over life of sensor (15 year typical)
- Pressure Dependence 0.13 % of reading per mm Hg
- Altitude Correction Programmable from 0-5000 ft via BACnet
- Response Time < 2 minutes for 90 % step change typical
- Warm-up Time < 2 minutes

Interface

- Hardware 2-wire RS-485
- Software Native BACnet MS/TP protocol
- Baud Rate Locally set to 9600, 19200, 38400 or 76800
- MAC Address Range Locally set to 0-127 (factory default is 3), (63 devices max on one daisy chain)

LCD Display

- Resolution 1 ppm CO2, 1 %RH, 1 °C (1 °F)
- Size 1.4” w x 0.6” h (35 x 15 mm) alpha-numeric 2 line x 8 characters
- Backlight Enable or disable via keypad

Optional Temperature Signal

Sensing Element 10K thermistor, ± 0.4 °F (± 0.2 °C)
 Resolution 0.2 °F (0.1 °C)
 Range 32-95 °F (0-35 °C)

Optional RH Signal

Sensor Thermoset polymer based capacitive
 Accuracy ± 2 %RH
 Range 0-100 %RH, non-condensing
 Resolution 1 %RH
 Hysteresis ± 3 %RH
 Response Time 15 seconds typical
 Stability ± 1.2 %RH typical @ 50 %RH in 5 years

Optional Relay Output

Contact Ratings Form A contact (N.O.), 2 Amps @ 140 Vac, 2 Amps @ 30 Vdc
 Relay Trip Point Programmable 500-1500 ppm via BACnet
 Relay Hysteresis Programmable 25-200 ppm via BACnet

Optional Override Switch . . Front panel push-button available as BACnet object

Optional Setpoint Control . . Front panel push-buttons available as 0 to 100 % as BACnet object

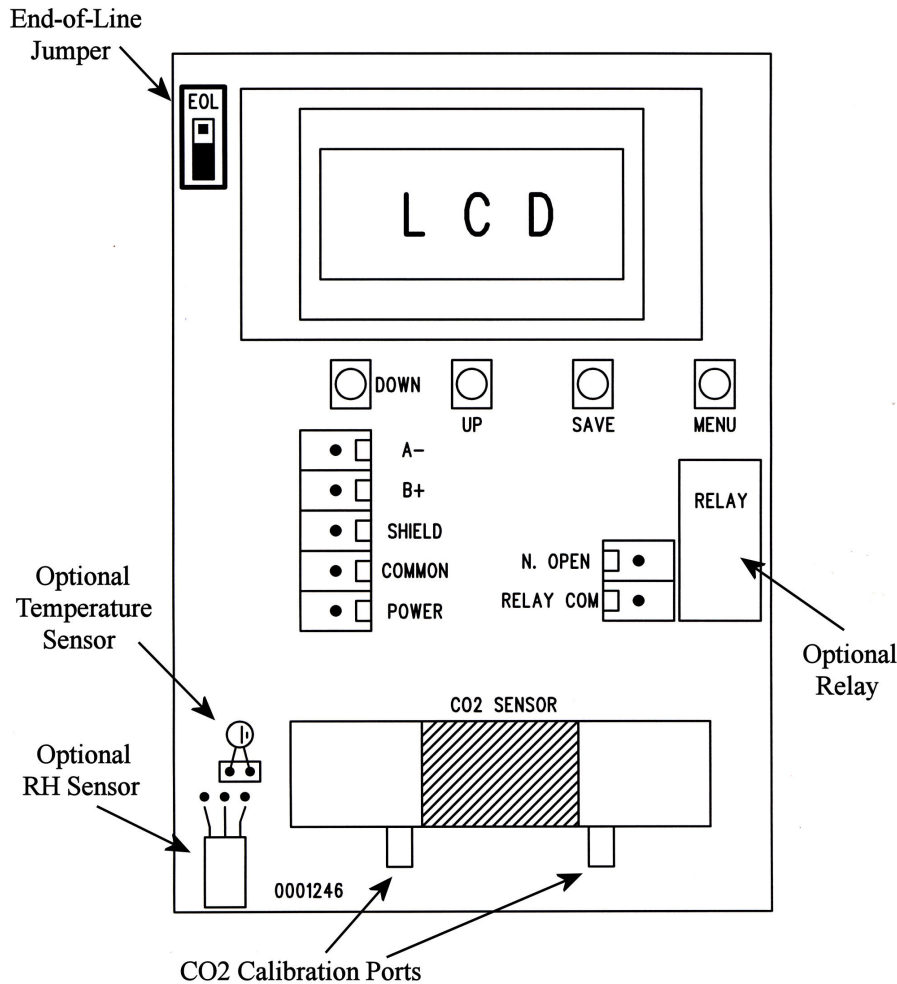

BACnet Protocol Implementation Conformance Statement (PICS)

Date : May 14, 2010
Vendor Name : Greystone Energy Systems Inc.
Product Name : CO2/RH/T Detector
Product Model Number : CDD2A-10-V-W-X-Y-Z, CDD2A-20-V-W-X-Y-Z
Application Software Version : 1.0
Firmware Revision : 1.4
BACnet Protocol Revision : 7

Product Description : The Greystone CO2/RH/T Detector is a smart room sensor with native BACnet MS/TP protocol for network communication. It measures room carbon dioxide (CO2) levels and reports this ppm value back to a building automation system (BAS). The device may also be configured with a relative humidity (RH) sensor to measure room %RH, a temperature sensor to measure room temperature in °C or °F, a setpoint control and override switch for user input, an alarm relay output and an LCD to display measured values.

BACnet Standardized Device Profile (Annex L) : BACnet Application Specific Controller (B-ASC)

BACnet Interoperability Building Blocks Supported (Annex K) : DS-RP-B, DS-WP-B,
DM-DDB-B, DM-DOB-B
DM-DCC-B

Segmentation Capability : Not supported

Standard Object Types Supported :

Object Type	Dynamically Creatable	Dynamically Deletable	Optional Properties Supported	Writable Properties
Device	No	No	Location, Description, Max_Master, Max_Info_Frames	Object_Identifier, Object_Name, Location, Description, APDU_Timeout, Max_Master, Number_Of_APDU_Retries
Analog Input	No	No	Description, Reliability, Device_Type	
Analog Value	No	No	Description	Present_Value
Binary Value	No	No	Description, Reliability	Present_Value
Binary Input	No	No	Description, Reliability, Device_Type	

Data Link Layer Options : MS/TP master (Clause 9), baud rates : 9600, 19200, 38400, 76800

Device Address Binding : Not supported

Networking Options : None

Character Set Supported : ANSI X3.4