

Pulse width modulated input to analog 0-10VDC output

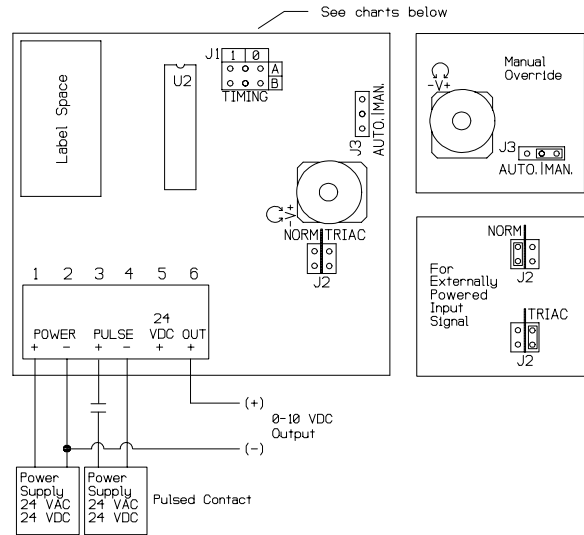
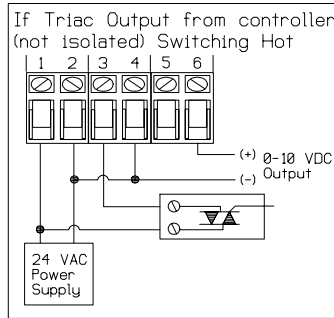
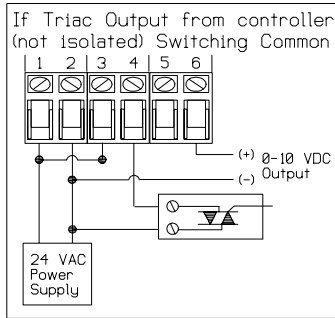
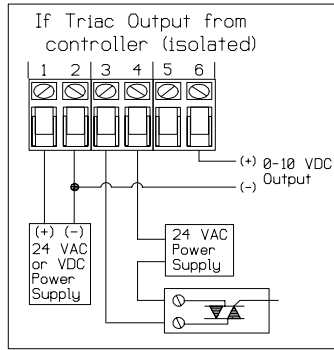
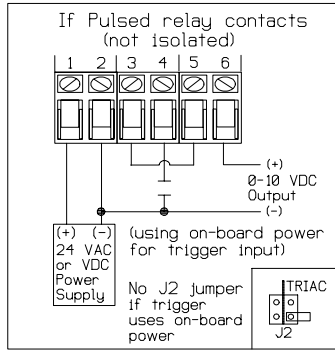

INPUT PULSE RANGES/VERSION 2

J1 Jumper Setting	1	0
0-10 Sec. Duty Cycle		
023-6 Sec.		
0304Y0B.Hex		

INPUT PULSE RANGES/VERSION 1

J1 Jumper Setting	1	0
.1-10 Sec.		
02-5 Sec.		
.1-25.5 Sec.		
.59-2.93 Sec.		
0114Y0E.Hex		

READ THESE INSTRUCTIONS BEFORE YOU BEGIN INSTALLATION

Ground yourself to discharge static electricity before touching any electronic equipment, as some components are static sensitive. The interface device can be mounted in any position. If circuit board slides out of snap track, a non-conductive "stop" may be required. Use only fingers to remove board from snap track. Slide out of snap track or push up against side of snap track and lift that side of the circuit board to remove. Do not flex board or use tools.

READ THESE INSTRUCTIONS BEFORE YOU BEGIN INSTALLATION.

Ground yourself before touching board. Some components are static sensitive.

MOUNTING:

Circuit board may be mounted in any position. If circuit board slides out of snap track, a nonconductive "stop" may be required. Use only fingers to remove board from snap track. Slide out of snap track or push against side of snap track and lift that side of the circuit board to remove. Do not flex board or use tools.

POWER CONNECTIONS -THIS PRODUCT ACCEPTS 24 VOLTS AC OR DC POWER

BE SURE TO FOLLOW ALL LOCAL AND ELECTRICAL CODES. REFER TO WIRING DIAGRAM FOR CONNECTION INFORMATION.

- 24 VDC** - with power off, connect 24 volt DC power supply to terminals POWER (+) and POWER (-) on the board.

24 VAC - with power off, connect one transformer secondary leg to the POWER (+) on the board. Connect the other transformer secondary leg to POWER (-). Check the wiring configuration of any other loads that may be connected to this transformer.

If required by BAS or controller specification, the 24 VAC neutral can be earth grounded at the transformer. Analog input, digital input, and analog output circuits should not be earth grounded at two points. Any field device connected to this transformer must use the same common. If you are not sure of other field device configuration, use separate transformers for isolation.
- If the 24 volt DC or AC power is shared with other devices that have coils such as relays, solenoids, or other inductors, each coil must have a diode or DC Transorb (if DC), a MOV or AC Transorb (if AC), or other spike snubbing device across each of the shared coils. Without these snubbers, coils produce very large voltage spikes when de-energizing that can cause malfunction or destruction of electronic circuits.
- You should measure the actual voltage output of the secondary. If the output is not fully loaded you may read a higher voltage than the circuit board can handle.

SETUP

Input pulse timing range is selected by placement of jumpers on J1 . Jumpers are factory set to 0.59-2.93 seconds. Refer to diagram above for timing ranges and positions.

Set Jumper J2 for normal or triac input if using external power for signal. No jumper if using on board power.

Set J3 for MAN in order to checkout connections by using manual override potentiometer. Reset J3 to AUTO for normal operation.

Explanation of Version #2, 0-10 Second Duty Cycle mode: PTA2 accepts a continuous pulse signal command string, sampled in a 10 second window. No pulse within a 10 second window produces minimum % output (0 volts). Ten second or continuous pulse produces a 100% output (10 volts).

TROUBLESHOOTING AND TESTING

1. Apply 24 VAC/VDC to "PWR" terminal and measure voltage to confirm proper voltage.
2. Check the input timing jumpers. Reset power if changes are made.
3. **Testing the output.** Connect power. Place Man/Auto jumper to Manual.
 0-10 VDC out: With meter only connected to the OUT (+) and POWER (-), turn the manual potentiometer full left and then full right. The output should vary from 0 to 100 %.
 If no change is seen, contact ACT tech support.
 If yes, connect load/device and meter to OUT (+) and PWR (-) terminals. Turn the override pot and measure voltage.
 Do the readings match the no load test?
 If no, check for load impedance mismatch or a possible ground loop problem and/or call ACT tech support.
 If yes, voltage output is functioning properly.
 Do not connect the output to OUT (+) and 24VDC (+). This will damage the unit within seconds.
4. **Testing the input.** To manually test the input.
 Apply 24 VAC/VDC to the PWR terminal. Connect your meter to the OUT (+) and POWER (-) terminal. Set meter for voltage. Place Man/Auto jumper to auto. Connect a jumper wire to the POWER (+) only. Connect another jumper wire to Pulse (-) and POWER (-). You are now ready to simulate a timed pulse signal. For testing purposes, select 0.1 to 10 second range. Be sure to reset power to allow the PTA2 to recognize new settings. Take the free end of the jumper wire from POWER (+) and connect by holding wire to the PULSE (+) terminal (be careful not to short it to POWER (-). Count to 5 seconds (or the time = to 50% of timing range) and remove. Verify the pulse LED indication. Read output.
 Has the output changed? The output should be close to 50% of set output.
 If no, change the TRC/NRM to the opposite setting and repeat test. Has the output changed? A voltage meter can be connected to the PULSE (+) and (-) terminals to verify voltage is present. If voltage is present and the output hasn't changed, contact ACT technical support. If the output has changed, unit is functioning properly.
 Remove all test wiring after completion of testing.

Power Supply		Timing Ranges:	
Supply Voltage	24 VAC or 24 VDC +/-10%, 50/60 Hz	Version 1:	.02-5 seconds, .1-10 seconds, .1-25.5 seconds, .59-2.93 seconds.
Supply Current	135 mA		
Power Consumption	3.24 watt	Version 2:	0-10 second Duty Cycle Pulse (a continuous pulse signal command string sampled in 10 sec. window) and .023-6 seconds.
Input:			
Relay, contact closure, transistor or triac	12-24 VAC/VDC signal trigger level or dry contact to common		
Signal Trigger Level:	Normal Mode: 5 to 26.4 VDC 5 to 26.4 VAC	Output:	Voltage: 0-10 VDC
	Triac Mode: 9 to 26.4 VAC	Impedance:	400 ohms minimum
	Rectified Power Output: 21 to 37 VDC	Rectified Power Output:	21 to 37 VDC (For input trigger only)
Impedance:	VAC-900 ohms nominal VDC-1500 ohms nominal		