

The WD-100 is a water detector incorporating microchip technology and gold-plated electrodes. This device can be operated from either an AC or DC supply and has a built-in fail-safe mechanism. The output of the detector is a reverse acting form "C" relay contact capable of switching 5 Amps at 250 Vac.

Fail-safe circuitry is incorporated in the WD-100 to signal an alarm condition in the event of a power loss or internal malfunction. This offers maximum security of the monitoring system.

The device is also available with a remote probe assembly.

**SPECIFICATIONS**

<b>Power Supply</b>	<b>14 - 32 V ac/dc</b>
<b>Power Consumption</b>	<b>60 mA max @ 24 Vdc (no water)</b>
<b>Operating Temperature</b>	<b>-40 to 85 C (-40 to 185 F)</b>
<b>Output Rating</b>	<b>Form "C" contacts 5 Amps @ 250 Vac (General use) 5 Amps @ 30 Vdc (Resistive)</b>

Fluids than can be detected	Fluids that can't be detected
City water	Pure water
Sea water	Gasoline
Copper sulfate solution	Oil
Weak acid	Brake fluid
Weak base	Alcohol
Household ammonia	Ethylene glycol
Water & glycol mixture	Paraffin
Wet soil	Dry soil
Coffee	Whiskey

**WIRING**

**Supply**

+ (plus)	Positive DC
- (minus)	Common
(blank)	Hot AC

**Output**

1	Normally Closed
2	Common
3	Normally Open

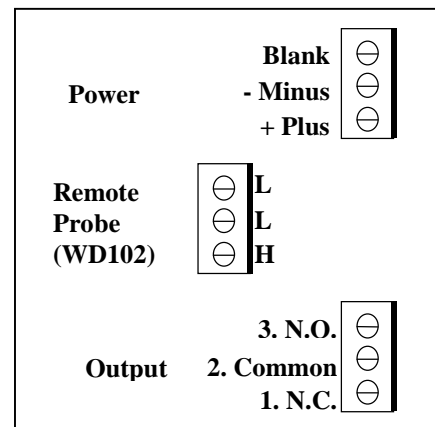

**Remote Probe (WD102)**

L	Remote Lead
H	Remote Lead

**Note :** The output state is shown in the powered state with no water present.