

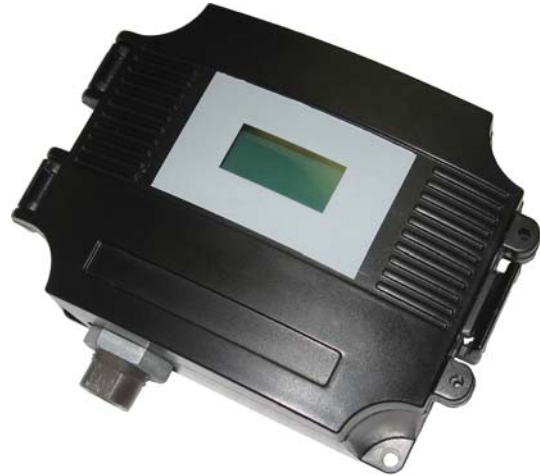

Model	Pressure Range			
	1	2	3	4
101	50 PSI	25 PSI	10 PSI	5 PSI
102	100 PSI	50 PSI	20 PSI	10 PSI
103	200 PSI	100 PSI	40 PSI	20 PSI
104	500 PSI	250 PSI	100 PSI	50 PSI
105	5.0 Bar	2.5 Bar	1.0 Bar	0.5 Bar
106	7.50 Bar	3.75 Bar	1.50 Bar	0.75 Bar
107	10 Bar	5 Bar	2 Bar	1 Bar
108	30 Bar	15 Bar	6 Bar	3 Bar
109	500 kPa	250 kPa	100 kPa	50 kPa
110	750 kPa	375 kPa	150 kPa	75 kPa
111	1000 kPa	500 kPa	200 kPa	100 kPa
112	3000 kPa	1500 kPa	600 kPa	300 kPa



WARNING Do not use in an explosive or hazardous environment, with combustible or flammable gasses, as a safety or emergency stop device or in any other application where failure of the product could result in personal injury. Use electrostatic discharge precautions during installation and do not exceed the device ratings.

MOUNTING The transmitter mounts on a vertical surface with the pressure ports and cable entrance on the bottom using the four screw holes on the base of the unit. Ensure there is enough space around the unit to make the pressure and electrical connections. Avoid locations with severe vibrations or excessive moisture. The enclosure has a standard 1/2" conduit opening and may be installed with either a conduit coupler or a cable gland type fitting. In this position the **High** port is on the left and the **Low** port is on the right as shown on the pcb.

WIRING Use 22 awg shielded wiring for all connections and do not locate the device wires in the same conduit with wiring used to supply inductive loads such as motors. Disconnect the power supply before making any connections to prevent electrical shock or equipment damage. Make all connections in accordance with national and local electrical codes.

This device is a 3-wire sourcing type transmitter. Connect the positive dc voltage or the hot side of the ac voltage to the terminal marked **PWR**. The power supply common is connected to the terminal marked **COM**. The device is reverse voltage protected and will not operate if connected backwards. The analog output signal is available on the **OUT** terminal. This signal is jumper selectable for either voltage or 4-20 mA output. In voltage mode, either 0-5 or 0-10 Vdc can also be selected. These options are indicated on the circuit board.

The remote zero feature may be used by wiring a dry-contact (relay only) digital output to the **ZERO** terminals. Do not apply voltage to the **ZERO** terminals.

PLUMBING Use an appropriately rated pressure tubing and arrange it to minimize stress on the connections. Do not allow material to fall into the pressure ports as contamination could damage the sensors.

CONFIGURATION As shown on the pcb drawing, push-on jumpers and switches are used to select the output signal type, the input pressure range and several features. The device is factory configured to operate in the 4-20 mA output mode but can be changed to voltage mode by moving the two jumpers from the positions marked **Current** to the positions marked **Voltage**. Always note the current jumper position first and then move them to the new position. If the jumpers are rotated 90 degrees and installed incorrectly the product will not work and damage may occur. In voltage mode the output scale may be changed to either 0-5 or 0-10 Vdc by moving the single jumper to the 5V or 10V position.

The Range and Options switches can be changed while the unit is operating. However, the output jumpers can only be changed while the power is removed.

The jumper marked **Light** is for the LCD back-light option. The back-light is enabled in the **On** position but can be set to **Off** to reduce power consumption.

The input pressure range (as shown on the product label) is set by moving the 4-position slide switch marked **RANGE**.

Slow damping and analog reverse functions are available by switching the appropriate DIP switch position to **ON**.

SLOW DAMPING This switch provides an 8-second averaging for surge dampening (normally it is 4-seconds).

OUTPUT REVERSE This switch reverses the output signal polarity. In reverse mode the analog output is maximum when the pressure differential is zero and decreases as pressure increases.

OPERATION For normal operation such as 0-100 PSI, the port is used to measure a positive pressure and 0 PSI = 4 mA and 100 PSI = 20 mA.

CALIBRATION With the port open to the ambient pressure, press and hold the auto-zero button or provide contact closure on the **ZERO** terminals for at least 3 seconds. Release the button or terminals and the device will calculate and store the new zero point. To protect the unit from accidental zeroing this feature is enabled only when the detected pressure on both ports is less than 5% of the full range. It is not recommended that the span calibration be performed in the field unless a high quality calibrator is available.

SPECIFICATIONS

Media compatibility	17-4 PH stainless steel
Input power	18 to 28 Vac/dc (non-isolated half-wave rectified)
Supply current @ 24 Vdc	100 mA with LCD backlight 35 mA with backlight disabled
Output signal	4-20 mA, 0-5 or 0-10 Vdc
Proof pressure	Max. 2x F.S. range
Burst pressure	Max. 5x F.S. range
Accuracy	+/- 1 %F.S. (range 4 is +/- 2 %)
Surge damping	4 sec averaging (8 sec for slow)
Long term stability	+/-0.25% typical (1 year)
Auto-zero adjust	pushbutton and remote input
Sensor operating range	-40 to 85 °C (-40 to 185 °F)
Operating environment	0 to 50 °C, 10 to 90 %RH n.c.
Fittings	1/8" NPT female
Enclosure	ABS with hinged lid and gasket, 5.7" w x 4" h x 2.5" d (145 x 102 x 63 mm)

WIRING

Power in, 24Vac/dc
Common is shared with output
Output, Current or Voltage.
Common is shared with power supply

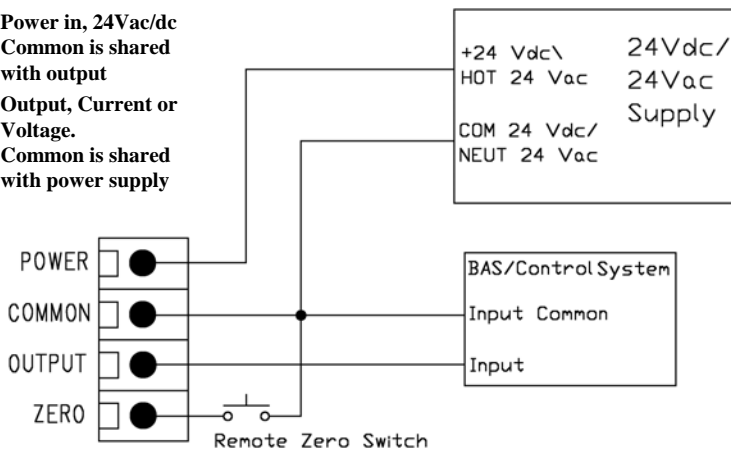

JUMPER SETTINGS

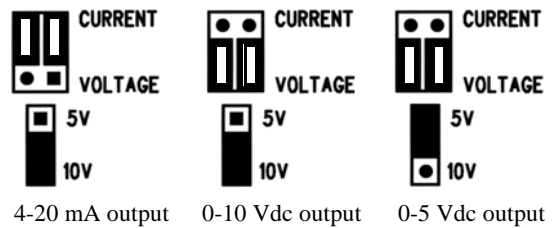

NOTE: The current/voltage output jumpers must be oriented as they are shown in the above illustration.

BOARD LAYOUT

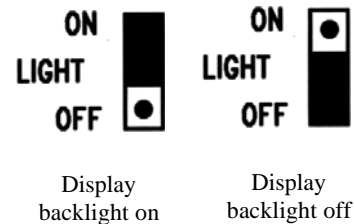
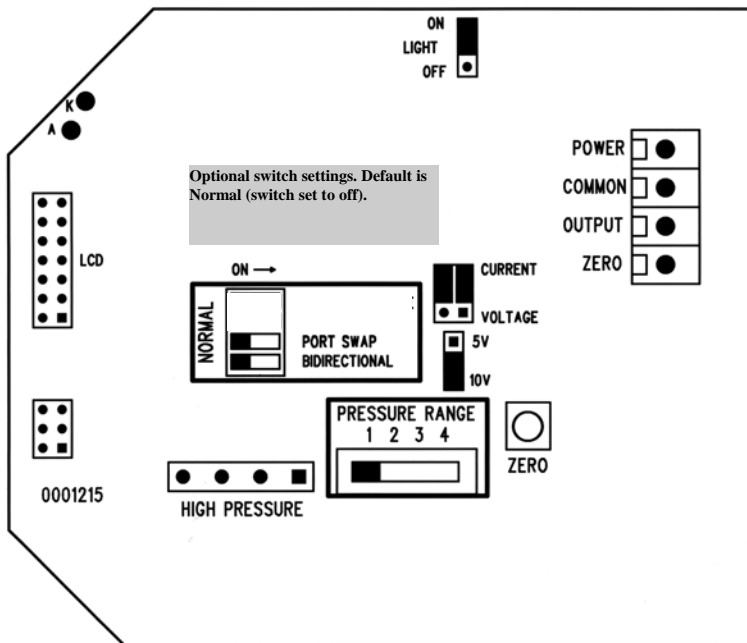

NOTE: The range and options switch can be changed while the unit is powered. However, the output jumpers can only be changed while the unit is unpowered.

DO NOT CONNECT POWER TO THE 'OUT' TERMINAL AS THE UNIT WILL BE DAMAGED!